

State Code	Year	District Code	Centre Code	Roll No.
<input type="text"/>	<input type="text"/>	<input type="text"/>	<input type="text"/>	<input type="text"/>

## STATE LEVEL NATIONAL TALENT SEARCH EXAMINATION, 2021 SCHOLASTIC APTITUDE TEST For Class X

Time : Scholastic Aptitude Test (Other Subjects) : For General - 120 Minutes, For Disabled (Only Blind) - 120 Minutes Full Marks : 100

### Instructions to Candidates

Read the following instructions carefully before you Answer the Questions.

**Answers are to be given on a separate OMR Answer-Sheet.**

- Please write your State Code, Year, District Code, Centre Code and Roll No. very clearly (only one digit in one Block) as given on your Admission Card. Please see that no Block is left unfilled and even zeros appearing in the State Code, Year, District Code, Centre Code and Roll No. are correctly transferred to the appropriate Block on the booklet and on the Answer-Sheet. **For example**, a student of Class X appearing from 'P' Centre, State Code '20', Year '21', District Code '99', Centre Code '99' with Roll No. '999', will make entries in the Block as well as darken the related circle by a Blue or Black Point Pen as under :-

State Code	Year	District Code	Centre Code	Roll No.
2 0	2 1	9 9	9 9	9 9 9
① ①	① ●	① ①	① ①	① ① ①
● ②	● ②	② ②	② ②	② ② ②
③ ③	③ ③	③ ③	③ ③	③ ③ ③
④ ④	④ ④	④ ④	④ ④	④ ④ ④
⑤ ⑤	⑤ ⑤	⑤ ⑤	⑤ ⑤	⑤ ⑤ ⑤
⑥ ⑥	⑥ ⑥	⑥ ⑥	⑥ ⑥	⑥ ⑥ ⑥
⑦ ⑦	⑦ ⑦	⑦ ⑦	⑦ ⑦	⑦ ⑦ ⑦
⑧ ⑧	⑧ ⑧	⑧ ⑧	⑧ ⑧	⑧ ⑧ ⑧
⑨ ⑨	⑨ ⑨	● ●	● ●	● ● ●
⑩ ●	⑩ ⑩	⑩ ⑩	⑩ ⑩	⑩ ⑩ ⑩

For all subsequent purposes your State Code, Year, District Code, Centre Code and Roll No. shall remain the same as given on the Admission Card.

- This Question Paper consists of 100 Questions.
- All questions carry 1 mark each.
- Since all questions are compulsory, do not try to read through the whole Question paper before beginning to answer it.
- Blank space has been provided for rough-work at the end of each subject.
- Remember you have to darken the circle of Answer-Sheet by a Blue or Black Ball Point Pen only; do not use a pencil.**
- Answer to each Question is to be indicated by darkening the circle by Blue or Black Ball Point Pen, the correct alternative in the Answer-Sheet from amongst the ones given for the corresponding Question in the question-booklet.
- Now turn to the next page and start answering the questions.
- English version of the question paper will be considered as final in case of any dispute arising out of the variation in translation.

**N.B.:** Do not write on Question-Booklet anything except the State Code, Year, District Code, Centre Code and Roll No. However, Rough Work can be done anywhere only in the space provided for it in the Booklet.

**SCHOLASTIC APTITUDE TEST****OTHER SUBJECTS**

Time : For General - 120 Minutes, For Disabled (Only Blind) - 150 Minutes

Full Marks : 100

**INSTRUCTIONS**

1. The subjects of Scholastic Aptitude Test are divided into three groups, as given below :

Sl. No.	Title of the group	Subjects covered under the group	Full Marks	No. of questions	Marks allotted to each question
(A)	Science Discipline	Physics, Chemistry and Biology	40	40	1 (one)
(B)	Mathematics	Mathematics	20	20	1 (one)
(C)	Social Studies and Humanities	History, Geography, Civics and Economics	40	40	1 (one)

**Please Turn Over the Page and Start Your Work.**

**PHYSICS**

1. In circular motion which one is correct

- (1) Constant Velocity (2) Zero Acceleration  
(3) Constant Speed (4) Speed change

**Ans. (Bonus)**

**Sol.** According to English version.

2. A car travels half distance with speed 20 m/sec and next half distance travel with 30 m/sec the average speed of the car is

- (1) Zero (2) 25 m/sec (3) 24 m/sec (4) 5 m/sec

**Ans. (3)**

**Sol.** 
$$V_{\text{avg}} = \frac{2v_1v_2}{v_1 + v_2} = \frac{2 \times 20 \times 30}{20 + 30} = \frac{2 \times 20 \times 30}{50} = 24 \text{ m/s.}$$

3. A body is travelling with speed 20 m/sec having acceleration 4 m/sec<sup>2</sup> the speed of the body after 2 sec is

- (1) 8 m/sec (2) 12 m/sec (3) 16 m/sec (4) 28 m/sec

**Ans. (4)**

**Sol.**  $v = u + at$

$$v = 20 + 4 \times 2 = 28 \text{ m/s.}$$

4. The weight of a body is 9.8 Newton, when  $g = 9.8 \text{ m/sec}^2$  the mass of the body is

- (1) Zero (2) 9.8 kg (3) 10 kg (4) 1 kg

**Ans. (4)**

**Sol.** Weight,  $w = mg$

$$\Rightarrow 9.8\text{N} = m \times 9.8 \text{ m/s}^2.$$

$$\therefore m = 1\text{kg}$$

5. Flying birds has

- (1) Only kinetic energy  
(2) Only potential energy  
(3) Both kinetic energy and potential energy  
(4) Only pressure energy

**Ans. (3)**

**Sol.** A flying bird has both potential energy and kinetic energy.

6. Two bodies of mass 2 gram and 4 gram having same kinetic energy having their ratio of linear momentum as

- (1) 2 : 1                      (2)  $\sqrt{2} : 1$                       (3) 1 : 2                      (4) 1 : 16

**Ans. (2)**

**Sol.** Kinetic Energy,  $K = \frac{p^2}{2m} \Rightarrow p = \sqrt{2mK}$

$$\frac{p_1}{p_2} = \frac{\sqrt{2m_1K_1}}{\sqrt{2m_2K_2}}$$

$$\therefore K_1 = K_2$$

$$\therefore \frac{p_1}{p_2} = \sqrt{\frac{m_1}{m_2}} = \sqrt{\frac{2}{4}} = \frac{1}{\sqrt{2}}$$

$$\therefore \frac{p_2}{p_1} = \frac{\sqrt{2}}{1}$$

7. The ratio of gravitational acceleration on the surface of Earth and Moon is

- (1)  $\sqrt{6} : 1$                       (2)  $1 : \sqrt{6}$                       (3) 1 : 6                      (4) 6 : 1

**Ans. (4)**

**Sol.**  $g_m = \frac{g_e}{6}$

$$\therefore \frac{g_e}{g_m} = \frac{6}{1}$$

8. The weight of a wooden block is w. The apparent weight of the body on a floating water.

- (1) w                      (2) more than w                      (3) less than w                      (4) Zero

**Ans. (4)**

**Sol.** Apparent weight = Real weight – Buoyant force.

$$\therefore W_{\text{app}} = W - F_B$$

Since the body floats hence,

$$W = F_B \therefore W_{\text{app}} = 0$$

9. In a simple Pendulum the displacement is equal to amplitude. Then kinetic energy will be

- (1) highest                      (2) Zero                      (3) No change                      (4) None

**Ans. (2)**

**Sol.** At maximum displacement of simple pendulum, Potential energy is maximum and kinetic energy is zero.

10. Heat and work done by the heat was discovered by

- (1) James Watt                      (2) Dr. D. Joule                      (3) Rudolf Diesel                      (4) Newcomen

**Ans. (BONUS)**

11. The focal length of a convex lens is 20 cm. The image formed is double the length of the object. The distance of the object from the lens is

- (1) -30 cm                      (2) -20cm                      (3) -60 cm                      (4) 30 cm

**Ans. (1)**

**Sol.**  $m = \frac{f}{f+u}$

$$\Rightarrow -2 = \frac{20}{20+u}$$

$$\Rightarrow -40 - 2u = 20$$

$$\Rightarrow -2u = 60$$

$$\therefore u = -30\text{cm}$$

12. An Electric motor takes 37.5 Amp. to start. Then its efficiency is

- (1) 1 Horse Power                      (2) 500 Watt  
(3) 54 Watt                      (4) 750 Horse Power

**Ans. (Bonus) Information is insufficient.**

13. The intensity of the bulb will decrease when a resistance is connected

- (1) In series  
(2) In parallel  
(3) Series or parallel  
(4) Intensity cannot be decreased

**Ans. (1)**

Sol.

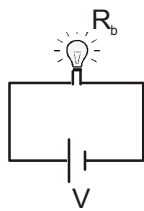

$$P = \frac{V^2}{R_b}$$

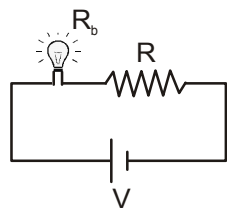

$$P' = \frac{V^2}{R_b + R}$$

Intensity  $\propto$  Power  $\propto$  brightness

Hence,  $P' < P$

So, When resistance is connected in series, intensity will decrease.

## CHEMISTRY

14. Assertion: 2-Bromobutane on reaction with sodium ethoxide in ethanol gives 2-butene as a major product.

Reason: 1-Butene is more stable than 2-butene.

Read the assertion and reason carefully to mark the correct option.

- (1) Both assertion and reason are true and the reason is the correct explanation of the assertion.
- (2) Both assertion and reason are true and the reason is not the correct explanation of the assertion.
- (3) Assertion is true but the reason is false.
- (4) Assertion is false but the reason is true.

Ans. (3)

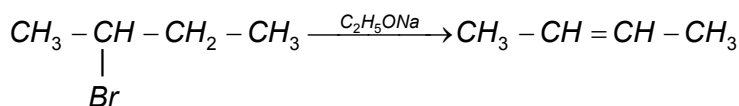

Sol.

$\text{CH}_3 - \text{CH} = \text{CH} - \text{CH}_3$  is more stable than 1-Butene. Because 2-Butene is more alkylated.

15.  $\text{KO}_2$  (Potassium superoxide) is used in oxygen cylinders in space and submarines because it

- (1) absorbs  $\text{CO}_2$  and increase  $\text{O}_2$  content.
- (2) eliminates moisture
- (3) absorbs  $\text{CO}_2$
- (4) produces Ozone

Ans. (1)

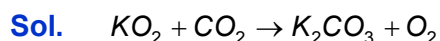

16. A solution of sodium sulphate in water is electrolysed using inert electrodes. The products at the anode and cathode are respectively

- (1)  $H_2, O_2$                       (2)  $O_2, H_2$                       (3)  $O_2, Na$                       (4)  $O_2, SO_2$

Ans. (2)

Sol. Anode  $4OH^- \rightarrow 4e^- + 2H_2O + O_2$

Cathode  $2H^+ + 2e^- \rightarrow H_2 \uparrow$

17. A substance on treatment with dilute  $H_2SO_4$  liberates a colourless gas which produces (i) turbidity with baryta solution and (ii) turns acidified dichromate solution green. The reaction indicates the presence of

- (1)  $CO_3^{2-}$                       (2)  $S^{2-}$                       (3)  $SO_3^{2-}$                       (4)  $NO_3^-$

Ans. (3)

Sol.  $SO_3^{2-} + H_2SO_4 \rightarrow SO_2$

$SO_2 + Ba(OH)_2 \rightarrow BaSO_3 + H_2O$

turbidity

$SO_2 + Cr_2O_7^{2-} \rightarrow SO_4^{2-} + Cr^{3+}$   
green solution

18. A gas formed by the action of alcoholic KOH on ethyl iodide decolourises alkaline  $KMnO_4$  solution, the gas is

- (1)  $CH_4$                       (2)  $C_2H_6$                       (3)  $C_2H_4$                       (4)  $C_2H_2$

Ans. (3)

Sol.  $CH_3 - CH_2 - I \xrightarrow[\text{KOH}]{\text{alc.}} CH_2 = CH_2$

$CH_2 = CH_2 \xrightarrow{KMnO_4} \begin{array}{c} CH_2 - CH_2 \\ | \quad | \\ OH \quad OH \end{array}$

19. Given pH of a solution A is 3 and it is mixed with another solution B having pH 2. The resultant pH of solution will be

- (1) 3.2                      (2) 1.9                      (3) 3.4                      (4) 3.5

Ans. (Bonus)

Sol. Assuming equal volume of both

$$V \times 10^{-3} + V \times 10^{-2} = 2V [H^+]$$

$$H^+ = \frac{1}{2} [11 \times 10^{-3}]$$

$$H^+ = 5.5 \times 10^{-3}$$

$$pH = 3 - \log 5.5 = 3 - .74 = 2.26$$

20. A light greenish salt is soluble in water. On passing  $H_2S$  gas into solution, a black precipitate is obtained which dissolves readily in  $HCl$ . The metal ion present is

- (1)  $Fe^{2+}$                       (2)  $Co^{2+}$                       (3)  $Ni^{2+}$                       (4)  $Mn^{2+}$

Ans. (1)

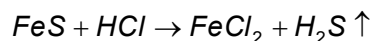
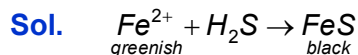

All sulphite except  $NiS$ ,  $CoS$ , are soluble in  $HCl$

21. Bonds present in  $CuSO_4 \cdot 5H_2O$  are

- (1) Electrovalent and covalent  
 (2) Electrovalent and Co-ordinate  
 (3) Electrovalent, covalent and Co-ordinate  
 (4) Covalent and Co-ordinate

Ans. (3)

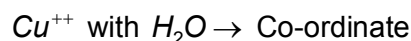
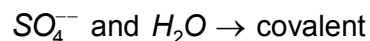
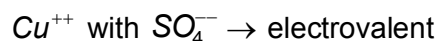

22. An organic compound (X) on treatment with acidified  $K_2Cr_2O_7$  gives a compound (Y) which reacts with  $I_2$  and sodium carbonate to form tri-iodomethane. The compound (X) is

- (1)  $CH_3OH$                       (2)  $CH_3 - \overset{O}{\parallel} C - CH_3$                       (3)  $CH_3CHO$                       (4)  $CH_3 - \underset{OH}{\text{CH}} - CH_3$

Ans. (4)

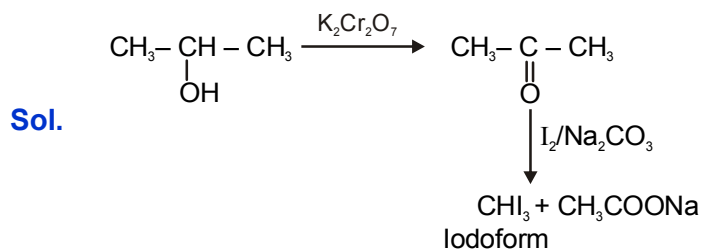



23. How many litres of  $\text{CO}_2$  at STP will be formed when 100 ml of 0.1 M  $\text{H}_2\text{SO}_4$  reacts with excess of  $\text{Na}_2\text{CO}_3$  ?

- (1) 22.4                      (2) 2.24                      (3) 0.224                      (4) 5.6

Ans. (3)

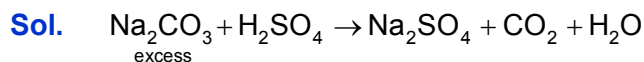

100 ml of 0.1 M                      .01 mole

10 milli mole

.01 mole

.01 mole  $\times$  22.4 = .224 L

24. Which compound has the weakest bond?

- (1) Diamond                      (2) Neon (Solid)                      (3) KCl                      (4) Water (ice)

Ans. (2)

Sol. Vander wall force (London force)

25. Which one of the following is used as antiknock compound?

- (1) Lead tetrachloride                      (2) Lead acetate  
 (3) Lead formate                      (4) Tetraethyl lead

Ans. (4)

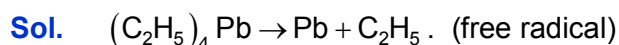

(Show antiknocking)

26. A bottle of ammonia and a bottle of dry hydrogen chloride connected through a long tube are opened simultaneously at both ends. The white ammonium-chloride ring first formed will be

- (1) At the centre of the tube  
 (2) Near the hydrogen chloride bottle  
 (3) Near the ammonia bottle  
 (4) Throughout the length of the tube

Ans. (2)

Sol.  $R(\text{diffusion}) \propto \frac{1}{\sqrt{\text{mol.wt}}}$

molecular wt.  $\text{NH}_3$  < molecular wt. HCl

So white fumes near HCl end.

**BIOLOGY**

27. The Xylem are responsible for

- (1) Transport of food in plants                      (2) Transport of water in plants  
(3) Transport of amino acids                      (4) Transport of oxygen

**Ans. (2)**

28. Which of the following is not a polymer ?

- (1) Cellulose              (2) Glycogen              (3) Protein              (4) Glucose

**Ans. (4)**

29. The disease that affects our lungs is

- (1) AIDS              (2) Rabies              (3) Polio              (4) Tuberculosis

**Ans. (4)**

30. Which of the following is not a plant hormone?

- (1) Auxin              (2) Florigen              (3) Cytokinin              (4) Oxytocin

**Ans. (4)**

31. Select the odd one from the following:

- (1) Stigma : Style : Ovary                      (2) Anther : Filament : Pollen  
(3) Cotyledon : Radicle : Plumule                      (4) Pollen : Pollen tube : Pellicle

**Ans. (4)**

32. The mode of nutrition in Fungi is

- (1) Autotrophic nutrition                      (2) Holozoic nutrition  
(3) Saprotrophic nutrition                      (4) Parasitic nutrition

**Ans. (3)**

33. Which of the following composition represents energy rich food?

- (1) Vitamins and minerals  
(2) Carbohydrates and fats  
(3) Water and roughage  
(4) Proteins and mineral salts

**Ans. (2)**

34. The products obtained during anaerobic respiration in plants are

- (1) Lactic acid + Energy  
(2) Pyruvic acid + Energy  
(3) Ethanol + Carbon dioxide + Energy  
(4) Carbon dioxide + Energy

**Ans. (2)**

35. What will happen if all the deer are killed in the given food chain?

Grass → Deer → Lion

- (1) The population of Lion increase
- (2) The population of grass decrease
- (3) The population of Lion decrease and grass increase
- (4) The population of Lion remain unchanged

**Ans. (3)**

36. The pores in a leaf through which respiratory exchange of gases takes place are

- (1) Xylem
- (2) Stigma
- (3) Lenticels
- (4) Stomata

**Ans. (4)**

37. When we destroy forest, we destroy

- (1) Population of wild life
- (2) The trees
- (3) The environment
- (4) Food and shelter of wild animals

**Ans. (4)**

38. Which of the following is not a natural resources?

- (1) Soil
- (2) Water
- (d) Electricity
- (4) Air

**Ans. (3)**

39. Pure Bred Pea Plant A is crossed with pure bred pea plant B. It is found that the plants which look like A do not appear in F1 generation but re-emerge in F2 generation, which of the plants A and B are tall and dwarf?

- (1) A are tall and B are also tall
- (2) A are tall and B are dwarf
- (3) A are dwarf and B are tall
- (4) A are dwarf and B are also dwarf

**Ans. (3)**

40. Pick the right combination of terms which has no fossil fuel -

- (1) Wind, Wood, Sun
- (2) Kerosene, Wind, Tide
- (3) Petroleum, Wood, Sun
- (4) Wind, Ocean, Coal

**Ans. (1)**

## MATHEMATICS

41. Three numbers prime to each other are such that the product of the first two is 437 and the product of the last two is 551. The sum of the numbers is .....

- (1) 59                      (2) 63                      (3) 69                      (4) 71

**Ans. (4)**

**Sol.** Let three numbers be  $x, y, z$

$$\gcd(x, y) = 1 \qquad \gcd(y, z) = 1 \qquad \& \gcd(x, z) = 1$$

given

$$xy = 437$$

$$yz = 551$$

$$xy = 19 \times 23$$

$$yz = 19 \times 29$$

$$\text{Sum of numbers} = 71$$

42. If the sum of the remainders obtained by dividing each of  $x^3 + 8x^2 - 3kx + 7$  and  $2x^3 + kx^2 - 5x + 6$  by  $x - 1$  is 9 then  $K = \dots\dots\dots$

- (1) 0                      (2) 2                      (3) 3                      (4) 5

**Ans. (4)**

**Sol.** Remainder when  $x^3 + 8x^2 - 3kx + 7$  is divided by  $x - 1$  is  $1 + 8 - 3k + 7 = 16 - 3k$

Remainder when  $2x^3 + kx^2 - 5x + 6$  is divided by  $x - 1$  is  $2 + k - 5 + 6 = 3 + k$

$$\text{Given } 16 - 3k + 3 + k = 9$$

$$\Rightarrow -2k = -10$$

$$\Rightarrow k = 5$$

43. A polynomial of degree 2 is divided respectively by  $x - 1, x - 2$  and  $x - 3$ . The remainders obtained are 1, 2 and 3 respectively. The polynomial is.....

- (1)  $x^2 - x + 1$               (2)  $x^2 - x + 2$               (3)  $\frac{1}{2}x^2 - \frac{1}{2}x + 2$               (4) None of these

**Ans. (4)**

**Sol.** Let polynomial of degree 2 is  $ax^2 + bx + c$

When  $ax^2 + bx + c$  is divided by  $x - 1$  gives remainder

$$\Rightarrow a + b + c = 1 \qquad \dots\dots\dots(1)$$

When  $ax^2 + bx + c$  is divided by  $x - 2$  gives remainder

$$\Rightarrow 4a + 2b + c = 2 \qquad \dots\dots\dots(2)$$

When  $ax^2 + bx + c$  is divided by  $x - 3$  gives remainder

$$\Rightarrow 9a + 3b + c = 3 \qquad \dots\dots\dots(3)$$

$$(2) - (1) \qquad \Rightarrow \qquad 3a + b = 1 \qquad \dots\dots\dots(4)$$

$$(3) - (2) \qquad \Rightarrow \qquad 5a + b = 1 \qquad \dots\dots\dots(5)$$

From (4) & (5)  $a = 0 \Rightarrow$  no such polynomial of degree 2 possible.

44. If the equations  $x^2 + bx + a = 0$  and  $x^2 + ax + b = 0$ , ( $a \neq b$ ) have equal roots then  $a + b = \dots\dots\dots$
- (1) -1                      (2) 0                      (3) 1                      (4) None of these

**Ans. (1)**

**Sol.** According to hindi version of question

$$x^2 + bx + a = 0 \quad \dots\dots(1)$$

$$x^2 + ax + b = 0 \quad \dots\dots(2)$$

$$(1) - (2)$$

$$(b - a)x + (a - b) = 0$$

$$\Rightarrow x = 1 \text{ is root of both equations}$$

$$\Rightarrow 1 + a + b = 0$$

$$\Rightarrow a + b = -1$$

According to English version of question

$$b^2 - 4a = 0 \quad \dots(1)$$

$$a^2 - 4b = 0 \quad \dots(2)$$

$$(2) - (1), (a^2 - b^2) + 4(a - b) = 0$$

$$\Rightarrow (a - b)(a + b + 4) = 0$$

$$\Rightarrow a + b = -4$$

Ans. (4)

45. In a right-angled triangle, the difference of the hypotenuse and the base is 2 cm. The hypotenuse exceeds twice the height by 1 cm. The base of the triangle is .....cm.

- (1) 8                      (2) 15                      (3) 17                      (4) 21

**Ans. (2)**

**Sol.** Given  $b - c = 2 \Rightarrow c = b - 2$

$$\& \quad b = 2a + 1 \Rightarrow a = \frac{b-1}{2}$$

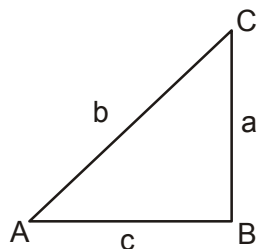

Also by Pythagoras theorem

$$b^2 = a^2 + c^2$$

$$\Rightarrow b^2 = \left(\frac{b-1}{2}\right)^2 + (b-2)^2$$

$$\Rightarrow b^2 = \left(\frac{b-1}{4}\right)^2 + (b-2)^2$$

$$\Rightarrow 4b^2 = b^2 - 2b + 1 + 4b^2 - 16b + 16$$

$$\Rightarrow b^2 - 18b + 17 = 0$$

$$\Rightarrow b^2 - 17b - b + 17 = 0$$

$$\Rightarrow b(b - 17) - 1(b - 17) = 0$$

$$\Rightarrow (b - 1)(b - 17) = 0$$

$$\Rightarrow b = 1, 17$$

$$\text{For } b = 1 \Rightarrow c = -1 \quad (\text{not possible})$$

$$\text{For } b = 17 \Rightarrow c = 15$$

46. By adding 1 to the sum of all natural numbers between 1 and 300, which are divisible by 7 and 8 a number p is obtained, then  $\sqrt{p} = \dots\dots\dots$

(1) 25

(2) 29

(3) 33

(4) 37

**Ans. (2)**

**Sol.** Numbers divisible by 7 and 8 between 1 and 300 is 56, 112, 168, 224, 280

$$\text{given,} \quad 56 + 112 + 168 + 224 + 280 + 1 = p$$

$$841 = p$$

$$\Rightarrow \sqrt{p} = 29$$

47. If in an A.P., the  $p^{\text{th}}$  term  $= \frac{1}{q}$  and the  $q^{\text{th}}$  term  $= \frac{1}{p}$ , then the  $pq^{\text{th}}$  term = .....

(1) -1

(2) 0

(3) 1

(4) None of these

**Ans. (3)**

**Sol.** Let first term be a and common difference be d

$$\text{Given} \quad T_p = \frac{1}{q} \Rightarrow a + (p-1)d = \frac{1}{q} \quad \dots\dots(1)$$

$$T_q = \frac{1}{p} \Rightarrow a + (q-1)d = \frac{1}{p} \quad \dots\dots(2)$$

$$(1) - (2)$$

$$(p-q)d = \frac{1}{q} - \frac{1}{p}$$

$$d = \frac{1}{pq}$$

$$\text{From (1) } a + (p-1)\frac{1}{pq} = \frac{1}{2}$$

$$a = \frac{1}{pq}$$

$$T_{pq} = a + (pq-1)d = \frac{1}{pq} + (pq-1)\frac{1}{pq} = 1$$

48. If  $x = 2^{\sin^2\theta}$ ,  $y = 2^{\cos^2\theta}$  for all real values of  $\theta$ , then

- (1)  $x + y = 1$       (2)  $x + y = 2$       (3)  $x + y \leq 2\sqrt{2}$       (4)  $x + y \geq 2\sqrt{2}$

**Ans. (4)**

**Sol.**  $x = 2^{\sin^2\theta}$ ,  $y = 2^{\cos^2\theta}$

$$\begin{aligned} x + y &= 2^{\sin^2\theta} + 2^{\cos^2\theta} \\ &= 2^{\sin^2\theta} + 2^{1-\sin^2\theta} \\ &= 2^{\sin^2\theta} + \frac{2}{2^{\sin^2\theta}} \end{aligned}$$

As  $2^{\sin^2\theta} > 0$

By  $AM \geq GM$

$$\frac{2^{\sin^2\theta} + \frac{2}{2^{\sin^2\theta}}}{2} \geq \sqrt{2^{\sin^2\theta} \times \frac{2}{2^{\sin^2\theta}}}$$

$$2^{\sin^2\theta} + \frac{2}{2^{\sin^2\theta}} \geq 2\sqrt{2}$$

$$\Rightarrow x + y \geq 2\sqrt{2}$$

49. If , for all real values of  $\theta$  ;  $a = \sin^2\theta + \cos^4\theta$  then

- (1)  $a \geq \frac{3}{4}$       (2)  $a \leq \frac{3}{4}$       (3)  $a = 1$       (4)  $a = \frac{1}{2}$

**Ans. (1)**

**Sol.**  $a = \sin^2\theta + \cos^4\theta$   
 $= 1 - \cos^2\theta + \cos^4\theta$

$$= 1 + \left( \cos^4 \theta - \cos^2 \theta + \frac{1}{4} - \frac{1}{4} \right)$$

$$= \frac{3}{4} + \left( \cos^2 \theta - \frac{1}{2} \right)^2$$

$$\Rightarrow a \geq \frac{3}{4}$$

50. If  $\sin \alpha + \cos \alpha = a$  and  $x = \sin^6 \alpha + \cos^6 \alpha$  then

- (1)  $x \leq 1$                       (2)  $x < 1$                       (3)  $x = 1$                       (4)  $x > 1$

Ans. (1)

Sol.  $x = \sin^6 \alpha + \cos^6 \alpha$

$$= (\sin^2 \alpha)^3 + (\cos^2 \alpha)^3$$

$$= (\sin^2 \alpha + \cos^2 \alpha) \cdot (\sin^4 \alpha + \cos^4 \alpha - \sin^2 \alpha \cdot \cos^2 \alpha)$$

$$= (\sin^2 \alpha + \cos^2 \alpha)^2 - 2 \sin^2 \alpha \cos^2 \alpha - \sin^2 \alpha \cos^2 \alpha$$

$$x = 1 - \frac{3}{4} (\sin 2\alpha)^2$$

$$x \leq 1$$

51. The angle of elevation of the top of a H m. high tower from two points A and B on the horizontal plane are  $60^\circ$  and  $30^\circ$  respectively. If the distance of A from the foot of the tower is 'a' m. then the distance of B from the foot of the tower will be .....m.

- (1)  $\frac{H^2}{a}$                       (2)  $\frac{2H^2}{a}$                       (3)  $\frac{\sqrt{H}}{a}$                       (4) None of these

Ans. (1)

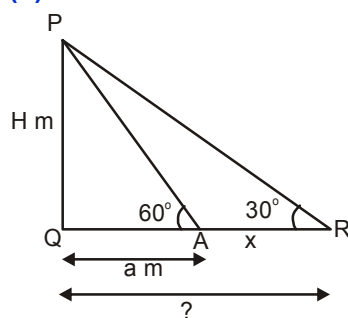

Sol.

$$\tan 60^\circ = \frac{H}{a}$$

$$H = a\sqrt{3}$$

$$\tan 30^\circ = \frac{H}{x+a}$$

$$\frac{1}{\sqrt{3}} = \frac{H}{x+a}$$



$$\therefore x + a = \sqrt{3} H$$

$$\therefore x = \sqrt{3} H - a$$

$$= \sqrt{3} \times a\sqrt{3} - a = 2a$$

Distance of B from the foot of tower

$$= 3a = 3 \times \frac{H}{\sqrt{3}} = 3 \times \frac{H \times H}{\sqrt{3} H} = \frac{H^2}{\left(\frac{H}{\sqrt{3}}\right)} = \frac{H^2}{a}$$

52. The co-ordinates of the vertices of a triangle are (3, 0), (0, 4) and (3, 4) respectively. The radius of the circle inscribed inside the triangle is .....units.

(1)  $\frac{1}{\sqrt{2}}$

(2)  $\sqrt{2}$

(3)  $\frac{1}{2}$

(4) 1

Ans. (4)

Sol. A(3,0)                      B(0, 4)                      C(3, 4)

Sides AB = 5                      BC = 3                      AC = 4

$\Delta$  ACB is a right angled triangle at vertex C.

Radius of the circle inscribed inside the triangle  $\frac{\Delta}{s} = \frac{6}{6} = 1$

53. In a  $\Delta$  ABC,  $\angle C = 90^\circ$ . On the sides CA and CB two points P and Q are taken such that they divide CA and CB in the ratio 2 : 1 respectively. Then,  $(AQ^2 + BP^2) : AB^2 = \dots\dots\dots$

(1)  $\frac{7}{9}$

(2)  $\frac{4}{9}$

(3)  $\frac{13}{9}$

(4)  $\frac{11}{9}$

Ans. (Bonus)

Sol. (in question  $Aa^2$  should be  $AQ^2$ ), then

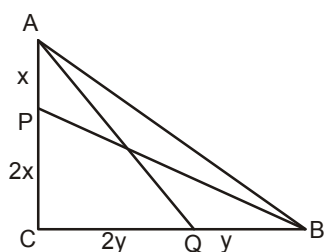

$$\frac{AQ^2 + BP^2}{AB^2} = \frac{(3x)^2 + 4y^2 + 4x^2 + 9y^2}{9x^2 + 9y^2}$$

$$\therefore \frac{9x^2 + 9y^2 + 4x^2 + 4y^2}{9(x^2 + y^2)} = \frac{13(x^2 + y^2)}{9(x^2 + y^2)}$$

$$= \frac{13}{9}$$

54. In  $\triangle ABC$ ,  $\angle C = 90^\circ$ . D is a point on CA from which a perpendicular drawn to AB meets it at E. If  $\angle EDA = \angle ABC$ ,  $BC = a$  cm.,  $AD = x$  cm.,  $AE = y$  cm.,  $BE = z$  cm., then  $DE = \dots\dots\dots$ cm.

- (1)  $\frac{ay}{z+x}$                       (2)  $\frac{az}{x+y}$                       (3)  $\frac{ax}{y+z}$                       (4) None of these

Ans. (3)

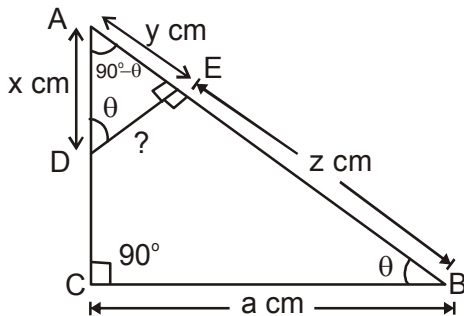

Sol.

$$\triangle AED \sim \triangle ACB$$

$$\frac{DE}{BC} = \frac{AE}{AC} = \frac{AD}{AB}$$

$$\frac{DE}{a} = \frac{x}{y+z}$$

$$\therefore DE = \frac{ax}{y+z}$$

55. Two circles of radii 9 cm. and 25 cm. touch each other externally. The length of a direct common tangent is  $\dots\dots\dots$ cm.

- (1) 15                      (2) 30                      (3)  $\sqrt{706}$                       (4)  $\sqrt{544}$

Ans. (2)

Sol.

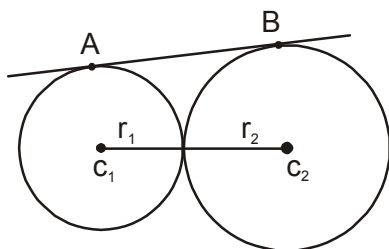

$r_1 = 9 \text{ cm}$

$r_2 = 25 \text{ cm}$

Length of DCT (Direct common tangent) =  $2\sqrt{r_1 r_2}$

$= 2\sqrt{9 \times 25} = 2 \times 3 \times 5 = 30 \text{ cm.}$

56. ABCD is a rectangle. Taking AD as diameter a semi-circle is drawn which cuts the diagonal DB at E. If AB = 12 cm. and AD = 9 cm. then BE = .....cm.

- (1) 9                                      (2) 9.6                                      (3) 10.2                                      (4) 10.6

Ans. (2)

Sol.

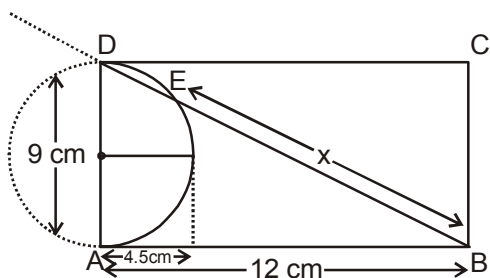

$AB^2 = BE \times BD$

$144 = x \times 15 \Rightarrow x = \frac{144}{15} = 9.6 \text{ cm}$

57. A semi-circular piece of paper of radius r cm. is folded to form a cone. The volume of the cone thus formed is ..... $\text{cm}^3$ .

- (1)  $\frac{\pi r^3}{\sqrt{3}}$                                       (2)  $\frac{\pi r^3}{8\sqrt{3}}$                                       (3)  $\frac{\pi r^3}{2\sqrt{3}}$                                       (4)  $\frac{\pi r^3}{4\sqrt{3}}$

Ans. (2)

Sol.

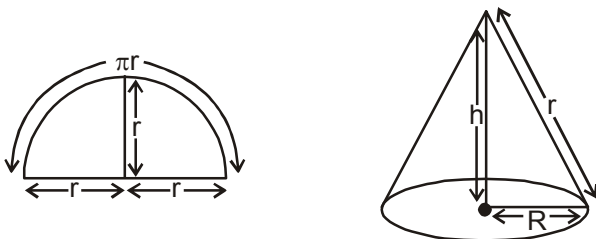

$\pi r = 2\pi R$

$\Rightarrow R = \frac{r}{2}$  .....(1)

$\therefore r^2 = h^2 + R^2 \Rightarrow h^2 = r^2 - \left(\frac{r}{2}\right)^2$

$$\Rightarrow h^2 = \frac{3r^2}{4} \Rightarrow h = \frac{\sqrt{3}}{2}r$$

$$\therefore \text{Volume (cone)} = \frac{1}{3}\pi R^2 h$$

$$= \frac{1}{3}\pi \left(\frac{r}{2}\right)^2 \times \frac{\sqrt{3}}{2}r = \frac{\sqrt{3}\pi r^3}{8} \times \frac{1}{3} = \frac{\pi r^3}{8\sqrt{3}}$$

58. A variable  $x$  takes the values  $x_1, x_2, \dots, x_n$ . Given  $\sum(x_i - 2) = 110$  and  $\sum(x_i - 5) = 20$ ,  $i = 1, 2, \dots, n$ , then  $n = \dots$

(1) 30

(2) 80

(3) 85

(4) 90

Ans. (1)

Sol.  $\sum_{i=1}^n (x_i - 2) = 110 \dots(i)$

$$\sum_{i=1}^n (x_i - 5) = 20 \dots(ii)$$

Now,  $(x_1 - 2) + (x_2 - 2) + \dots + (x_n - 2) = 110$

$$\Rightarrow (x_1 + x_2 + x_3 + \dots + x_n) - 2n = 110$$

$$\Rightarrow x_1 + x_2 + \dots + x_n = 2n + 110 \dots(iii)$$

Also  $\sum_{i=1}^n (x_i - 5) = 20$

$$\Rightarrow (x_1 + x_2 + x_3 + \dots + x_n) - 5n = 20$$

$$\Rightarrow x_1 + x_2 + \dots + x_n = 5n + 20 \dots(iv)$$

From (iii) & (iv)

$$5n + 20 = 2n + 110$$

$$\Rightarrow 3n = 90 \Rightarrow n = 30$$

59. C is the mid-point of the line segment AB of length L cm. Two points P and Q are taken randomly on the line segments CA and CB. Then, the probability for  $PQ < \frac{1}{2}$  is .....

(1)  $\frac{1}{2}$ (2)  $\frac{1}{4}$ (3)  $\frac{1}{8}$ 

(4) None of these

Ans. (Bonus)

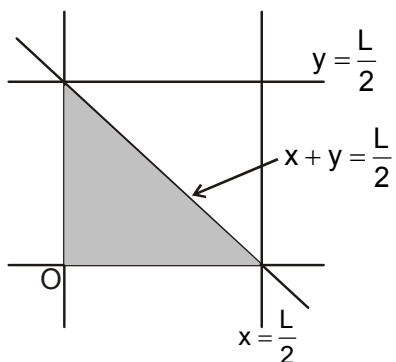

Sol.

There should be a correction in the question if (i.e  $PQ < \frac{L}{2}$  instead of  $PQ < \frac{1}{2}$ )

Let  $CP = x$  &  $CQ = y$

Obviously  $0 \leq x \leq \frac{L}{2}$  and  $0 \leq y \leq \frac{L}{2}$

We require  $x + y < \frac{L}{2}$

$$\text{Required prob.} = \frac{\text{Area of shaded region}}{\text{Total area}} = \frac{\frac{1}{2} \times \frac{L}{2} \times \frac{L}{2}}{\frac{L}{2} \times \frac{L}{2}} = \frac{1}{2}$$

60. If a, b, c, d denote the sides of a quadrilateral ABCD then,

$$\frac{a}{b+c+d} + \frac{b}{c+d+a} + \frac{c}{a+b+d} + \frac{d}{a+b+c} \text{ is}$$

- (1)  $< 1$                       (2)  $\geq 1$                       (3)  $> 1$                       (4) None of these

Ans. (4)

Sol. Let  $E = \frac{a}{b+c+d} + \frac{b}{c+d+a} + \frac{c}{a+b+d} + \frac{d}{a+b+c}$

$$\Rightarrow E + 4 = \underbrace{\left(\frac{a+b+c+d}{b+c+d}\right)}_x + \underbrace{\left(\frac{b+c+d+a}{c+d+a}\right)}_y + \underbrace{\left(\frac{c+a+b+d}{a+b+d}\right)}_z + \underbrace{\left(\frac{d+a+b+c}{a+b+c}\right)}_w$$

Now,  $A.M \geq H.M$

$$\frac{x+y+z+w}{4} \geq \frac{4}{\frac{1}{x} + \frac{1}{y} + \frac{1}{z} + \frac{1}{w}} \Rightarrow \frac{E+4}{4} \geq \frac{4}{3}$$

$$\Rightarrow E \geq \frac{16}{3} - 4 \Rightarrow E \geq \frac{4}{3}$$

**HISTORY**

61. After the defeat of Napoleon where did the Victor Powers assemble in 1815 ?

- (1) Vienna                      (2) London                      (3) Paris                      (4) Rome

**Ans. (1)**

62. Which dynasty succeeded the Bourbon dynasty after the 1830 revolution?

- (1) Habsburg                      (2) Orleans                      (3) Tsardom                      (4) None of these

**Ans. (2)**

63. Charles Albert was the King of which country?

- (1) Naples                      (2) Parma                      (3) Modena                      (4) Sardinia

**Ans. (4)**

64. What was Zollverein?

- (1) Intellectual's Union                      (2) Clergy's Union  
(3) Revolutionaries Union                      (4) Trader's Union

**Ans. (4)**

65. When was Karl Marx born?

- (1) 1810                      (2) 1818                      (3) 1825                      (4) 1830

**Ans. (2)**

66. Who was the author of 'War and Peace'?

- (1) Tolstoy                      (2) Kari Marx                      (3) Lenin                      (4) St. Simon

**Ans. (1)**

67. Who built the Angkorwat Temple?

- (1) Jayavarman                      (2) Suryavarman II  
(3) Mahendrarvarman                      (4) Rudrarvarman

**Ans. (2)**

68. In 1878 which Viceroy passed the "Vernacular Press Act" ?

- (1) Lord Ripon                      (2) Lord Lytton                      (3) Lord Curzon                      (4) Lord Chelmsford

**Ans. (2)**

69. Who established the Ramakrishna Mission?

- (1) Ramkrishna Paramhans                      (2) Ishwar Chandra Vidyasagar  
(3) Swami Vivekananda                      (4) Devendra Nath Thakur

**Ans. (3)**

70. After which incident Rabindra Nath Tagore surrendered the title "Knight" ?
- (1) Rowlatt Act (2) Khilafat Movement  
(3) Jallianwala Bagh massacre (4) Coming of Simon Commission

Ans. (3)

71. Who invented the "Safety Lamp" ?
- (1) Humphrey Dury (2) Richard Arkwright  
(3) James Hargreaves (4) Edmund Cartwright

Ans. (1)

72. Who published the newspaper "Som Prakash" ?
- (1) Ishwar Chandra Vidyasagar (2) Bal Gangadhar Tilak  
(3) Ram Mohan Roy (4) M. G. Ranade

Ans. (1)

## GEOGRAPHY

73. Bharatpur Bird sanctuary is situated in
- (1) Gujarat (2) Rajasthan (3) Assam (4) Bihar

Ans. (2)

74. The highest Literacy rate in India is in \_\_\_\_ ? .
- (1) West Bengal (2) Maharashtra (3) Kerala (4) Punjab

Ans. (3)

75. Where is ropeway in Bihar?
- (1) Bihar Sharif (2) Rajgir (3) Gaya (4) Munger

Ans. (2)

76. Select the correct statements
- (a) Koshi river is sorrow of Bihar.  
(b) Parrot is the national bird of India.  
(c) Maruti Industry is situated in Delhi.  
(d) Varanasi is situated on the bank of river ganges.
- (1) a and d (2) b and c (3) b, c and d (4) a, c and d

Ans. (1)

77. Which one is correct?
- (1) Jammu and Kashmir - Jajila (2) Himachal Pradesh - Thagla  
(3) Uttarakhand - Nathula (4) Sikkim - Shipkila

Ans. (1)

78. Which name is correct for Patna Airport ?

- (1) Jai Prakash Narayan International Airport
- (2) Patna Airport
- (3) Rajendra Prasad International Airport
- (4) Bihar Airport

**Ans. (1)**

79. The main problems of industrial backwardness of Bihar is

- (1) Lack of raw material
- (2) Lack of capital/money
- (3) Lack of electricity
- (4) All of the above

**Ans. (4)**

80. Which statement is not correct?

- (a) Medha Patekar is related with Narmada Bachao Andolan.
  - (b) New alluvial soil is termed as Bangar.
  - (c) Mangrove Forest found in the coastal area of India.
  - (d) Plantation agriculture is one of the type of commercial farming.
- (1) a                      (2) b                      (3) b, c and d                      (4) c and d

**Ans. (2)**

81. Which of the following cities are located on the Western Coast of India?

- (1) Puri, Chennai, Vishakhapatnam
- (2) Hyderabad, Nagpur, Bengaluru
- (3) Kozhikode (Calicut), Goa, Mumbai
- (4) Amrawati, Puna, Pudduchery (Pondicherry)

**Ans. (1)**

82. Select the correct statements

- (a) Mount K<sup>2</sup> is the highest peak of India
  - (b) Sunderban is in West Bengal
  - (c) Nuclear disaster is very dangerous for the world.
  - (d) Cactus plants found in evergreen forest.
- (1) a and b                      (2) a and c                      (3) a, b and c                      (4) a, b and d

**Ans. (3)**



83. The Golden Quadrilateral Super highway connected with the following

- (1) Jammu, Bikaner, Jodhpur, Rajkote
- (2) Porbandar, Bikaner, Amritsar, Srinagar
- (3) Delhi, Mumbai, Chennai, Kolkata
- (4) Sikkim, Siliguri, Jorhat, Agartalla

Ans. (3)

84. Select the correct statements

- (a) Muscovite is known as Bengal Ruby.
- (b) Gold is metallic mineral.
- (c) Kahalgaon Super Thermal Power is in Uttar Pradesh.
- (d) Anthracite is one type of iron.

- (1) a                      (2) a and b                      (3) a, band c                      (4) a, band d

Ans. (Bonus)

## CIVICS

85. Which one of the following term is not included in the preamble to the Indian Constitution?

- (1) Republic              (2) Justice              (3) Monarchy              (4) Equality

Ans. (3)

86. Which of the following does not lead to the spread of democracy?

- (1) Struggle by people
- (2) Invasion by Foreign Government
- (3) End of Colonialism
- (4) People's desire for freedom

Ans. (2)

87. Which one of the following statement about the Indian President is true?

- (1) He appoints Chief Minister in States.
- (2) He exercises real power.
- (3) He is elected directly by the people.
- (4) He is the formal head in the Country.

Ans. (4)

88. Which of the following institutions can amend the Constitution of India?

- (1) The Parliament
- (2) The Cabinet
- (3) The Prime Minister
- (4) The President

Ans. (1)

89. Which of the following are the features of Federal Government?

- (I) Unwritten Constitution (II) Division of Powers  
 (III) Single Citizenship (IV) Independent Judiciary  
 (1) I and II (2) II and III (3) I and IV (4) II and IV

Ans. (4)

90. Dealing with social divisions which one of the following statement IS not true about democracy?

- (1) Democracy is the best way to accommodate social diversity.  
 (2) Democracy always leads to disintegration of society.  
 (3) In a democracy, it is possible for communities to voice their grievances in a peaceful manner.  
 (4) Due to political competition in a democracy, social division get reflected in politics.

Ans. (2)

91. What do the civil servants do ?

- (1) They take policy decisions. (2) They implement minister's decision.  
 (3) They settle the disputes. (4) None of these

Ans. (2)

92. Which one of the following does not help in the formation of Public Opinion?

- (1) Newspaper (2) Radio  
 (3) Playground (4) Educational Institutional

Ans. (3)

## ECONOMICS

93. At present which form of money is increasingly used apart from paper money?

- (1) Commodity money (2) Metallic money  
 (3) Plastic money (4) All of the above

Ans. (3)

94. Choose the correct combination

<u>Standardized Marks</u>	<u>Product</u>
(i) ISI	(a) Jewellery
(ii) FPO	(b) Electrical
(iii) Hallmark	(c) Food
(iv) Agmark	(d) Agricultural Product
(1) i-a, ii-b, iii-c, iv-d	(2) i-c, ii-d, iii-a, iv-b
(3) i-b, ii-c, iii-a, iv-d	(4) i-d, ii-c, iii-b, iv-a

Ans. (3)

95. There are 1000 households in the village of Almora, of which the loan taken by 200 households are from the State Bank of India, another 200 households from their friends and relatives, 50 households from Indian Bank, 100 households from Regional Rural Bank, 150 households from businessmen, 100 households from village headmen and 200 households from cooperative societies. Which of the following statements is/are correct?

- I. Formal sources of credit are lower than the others.
- II. Institutional sources of credit are higher than others .
- III. Non-institutional sources of credit are higher than others.
- IV. Informal sources of credit are higher than others.

(1) Only I                      (2) Only II                      (3) I and II                      (4) III and IV

**Ans. (2)**

96. Which of the following statements about Sustainable Development is/are correct?

- I. The word 'Sustainable Development' came into existence in the year 1980.
- II. Sustainable Development is development that meets the needs of the present without compromising the ability of future generations to meet their own needs.
- III. Brundtland Commission is related to Sustainable Development.

(1) I and II                      (2) I and III                      (3) Only II                      (4) I, II and III

**Ans. (4)**

97. Which of the following statements is/are correct about the NITI Aayog ?

- I. NITI Aayog was established on 1 January 2015.
- II. The Prime Minister of India is the ex officio Chairperson of the NITI Aayog.
- III. NITI, Aayog replaced the Planning Commission of India in 2014.

(1) I and II                      (2) II and III                      (3) Only I                      (4) I, II and III

**Ans. (1)**

98. Mixed Economy means an economy where there is

- (1) Existence of capitalism
- (2) Privatization, liberalization and globalization
- (3) Existence of both public and private sectors.
- (4) Growing crops along with rearing animals

**Ans. (3)**

99. Which of the following is not a function of the commercial bank in an economy?

- (1) Accepting Deposits
- (2) Providing Loans
- (3) Locker Facilities
- (4) Acting as a Banker's Bank

**Ans. (4)**

100. If GDP for a country X is \$130 million in 2020 and its population is 20,000, GDP per capita is

- (1) 6500
- (2) 130
- (3) 0.0065
- (4) 650

**Ans. (1)**